



Mr. SLIM

# Air-Conditioners

## PUZ-ZM•KA Series

## PUZ-ZM•KA-ET Series

### INSTALLATION MANUAL

FOR INSTALLER

For safe and correct use, read this manual and the indoor unit installation manual thoroughly before installing the air-conditioner unit.

English



# Manual Download



<http://www.mitsubishielectric.com/ldg/ibim/>

- en** Go to the above website to download manuals, select model name, then choose language.
- de** Besuchen Sie die oben stehende Website, um Anleitungen herunterzuladen, wählen Sie den Modellnamen und dann die Sprache aus.
- fr** Rendez-vous sur le site Web ci-dessus pour télécharger les manuels, sélectionnez le nom de modèle puis choisissez la langue.
- nl** Ga naar de bovenstaande website om handleidingen te downloaden, de modelnaam te selecteren en vervolgens de taal te kiezen.
- es** Visite el sitio web anterior para descargar manuales, seleccione el nombre del modelo y luego elija el idioma.
- it** Andare sul sito web indicato sopra per scaricare i manuali, selezionare il nome del modello e scegliere la lingua.
- el** Μεταβείτε στον παραπάνω ιστότοπο για να κατεβάσετε εγχειρίδια. Επιλέξτε το όνομα του μοντέλου και, στη συνέχεια, τη γλώσσα.
- pt** Aceda ao site Web acima indicado para descarregar manuais, seleccione o nome do modelo e, em seguida, escolha o idioma.
- da** Gå til ovenstående websted for at downloade manualer og vælg modelnavn, og vælg derefter sprog.
- sv** Gå till ovanstående webbplats för att ladda ner anvisningar, välj modellnamn och välj sedan språk.
- tr** Kılavuzları indirmek için yukarıdaki web sitesine gidin, model adını ve ardından dili seçin.
- ru** Чтобы загрузить руководства, перейдите на указанный выше веб-сайт; выберите название модели, а затем язык.
- uk** Щоб завантажити керівництва, перейдіть на зазначений вище веб-сайт; виберіть назву моделі, а потім мову.
- bg** Посетете горепосочения уебсайт, за да изтеглите ръководства, като изберете име на модел и след това – език.
- pl** Odwiedź powyższą stronę internetową, aby pobrać instrukcje, wybierz nazwę modelu, a następnie język.
- no** Gå til nettstedet over for å laste ned håndbøker og velg modellnavn, og velg deretter språk.
- fi** Mene yllä mainitulle verkkosivulle ladataksesi oppaat, valitse mallin nimi ja valitse sitten kieli.
- cs** Příručky naleznete ke stažení na internetové stránce zmíněné výše poté, co zvolíte model a jazyk.
- sk** Na webovej stránke vyššie si môžete stiahnuť návody. Vyberte názov modelu a zvolte požadovaný jazyk.
- hu** A kézikönyvek letöltéséhez látogasson el a fenti weboldalra, válassza ki a modell nevét, majd válasszon nyelvet.
- sl** Obiščite zgornjo spletno stran za prenos priročnikov; izberite ime modela, nato izberite jezik.
- ro** Accesați site-ul web de mai sus pentru a descărca manualele, selectați denumirea modelului, apoi alegeți limba.
- et** Kasutusjuhendite allalaadimiseks minge ülaltoodud veebilehele, valige mudeli nimi ja seejärel keel.
- lv** Dodieties uz iepriekš norādīto tīmekļa vietni, lai lejupielādētu rokasgrāmatas; tad izvēlieties modeļa nosaukumu un valodu.
- lt** Norėdami atsisiųsti vadovus, apsilankykite pirmiau nurodytoje žiniatinklio svetainėje, pasirinkite modelio pavadinimą, tada – kalbą.
- hr** Kako biste preuzeli priručnike, idite na gore navedeno web-mjesto, odaberite naziv modela, a potom odaberite jezik.
- sr** Idite na gore navedenu veb stranicu da biste preuzeli uputstva, izaberite ime modela, a zatim izaberite jezik.

# Contents

1. Safety precautions . . . . .	1	6. Electrical work . . . . .	12
2. Installation location . . . . .	3	7. Test run . . . . .	14
3. Installing the outdoor unit . . . . .	8	8. Special functions . . . . .	14
4. Installing the refrigerant piping . . . . .	8	9. System control (Fig. 9-1) . . . . .	15
5. Drainage piping work . . . . .	12	10. Specifications . . . . .	15



**Note: This symbol mark is for EU countries only.**  
**This symbol mark is according to the directive 2012/19/EU Article 14 Information for users and Annex IX.**  
 Your MITSUBISHI ELECTRIC product is designed and manufactured with high quality materials and components which can be recycled and reused. This symbol means that electrical and electronic equipment, at their end-of-life, should be disposed of separately from your household waste. Please, dispose of this equipment at your local community waste collection/recycling centre.  
 In the European Union there are separate collection systems for used electrical and electronic product.  
 Please, help us to conserve the environment we live in!

**⚠ Caution:**  
 • Do not vent R32 into the atmosphere.

## 1. Safety precautions

- ▶ Before installing the unit, make sure you read all the "Safety precautions".
- ▶ Please report to or take consent by the supply authority before connection to the system.
- ▶ Equipment complying with IEC/EN 61000-3-12 (PUZ-ZM100/125/140V)

**⚠ Warning:**  
 Describes precautions that must be observed to prevent danger of injury or death to the user.

**⚠ Caution:**  
 Describes precautions that must be observed to prevent damage to the unit.

After installation work has been completed, explain the "Safety Precautions," use, and maintenance of the unit to the customer according to the information in the Operation Manual and perform the test run to ensure normal operation. Both the Installation Manual and Operation Manual must be given to the user for keeping. These manuals must be passed on to subsequent users.

**⚡** : Indicates a part which must be grounded.

**⚠ Warning:**  
 Carefully read the labels affixed to the main unit.  
**⊙** : Indicates warnings and cautions when using R32 refrigerant.

### MEANINGS OF SYMBOLS DISPLAYED ON THE UNIT

	<b>WARNING</b> (Risk of fire)	This mark is for R32 refrigerant only. Refrigerant type is written on nameplate of outdoor unit. In case that refrigerant type is R32, this unit uses a flammable refrigerant. If refrigerant leaks and comes in contact with fire or heating part, it will create harmful gas and there is risk of fire.
		Read the OPERATION MANUAL carefully before operation.
		Service personnel are required to carefully read the OPERATION MANUAL and INSTALLATION MANUAL before operation.
		Further information is available in the OPERATION MANUAL, INSTALLATION MANUAL, and the like.

- ⚠ Warning:**
- The unit must not be installed by the user. Ask a dealer or an authorized technician to install and repair the unit. If the unit is installed incorrectly, water leakage, electric shock, or fire may result.
  - For installation and relocation work, follow the instructions in the Installation Manual and use tools and pipe components specifically made for use with R32 refrigerant. If pipe components not designed for R32 refrigerant are used and the unit is not installed correctly, the pipes may burst and cause damage or injuries. In addition, water leakage, electric shock, or fire may result.
  - When installing the unit, use appropriate protective equipment and tools for safety. Failure to do so could cause injuries.
  - The unit must be installed according to the instructions in order to minimize the risk of damage from earthquakes, typhoons, or strong winds. An incorrectly installed unit may fall down and cause damage or injuries.
  - The unit must be securely installed on a structure that can sustain its weight. If the unit is mounted on an unstable structure, it may fall down and cause damage or injuries.
  - If the air conditioner is installed in a small room, measures must be taken to prevent the refrigerant concentration in the room from exceeding the safety limit in the event of refrigerant leakage. Consult a dealer regarding the appropriate measures to prevent the allowable concentration from being exceeded. Should the refrigerant leak and cause the concentration limit to be exceeded, hazards due to lack of oxygen in the room may result.
  - Ventilate the room if refrigerant leaks during operation. If refrigerant comes into contact with a flame, poisonous gases will be released.
  - All electric work must be performed by a qualified technician according to local regulations and the instructions given in this manual. The units must be powered by dedicated power lines and the correct voltage and circuit breakers must be used. Power lines with insufficient capacity or incorrect electrical work may result in electric shock or fire.
  - Use C1220 copper phosphorus, for copper and copper alloy seamless pipes, to connect the refrigerant pipes. If the pipes are not connected correctly, the unit will not be properly grounded and electric shock may result.
  - This appliance is intended to be used by expert or trained users in shops, in light industry and on farms, or for commercial use by lay persons.
  - Use only specified cables for wiring. The wiring connections must be made securely with no tension applied on the terminal connections. Also, never splice the cables for wiring (unless otherwise indicated in this document). Failure to observe these instructions may result in overheating or a fire.
  - If the supply cord is damaged, it must be replaced by the manufacturer, its service agent or similarly qualified persons in order to avoid hazard.
  - The appliance shall be installed in accordance with national wiring regulations.
  - The terminal block cover panel of the outdoor unit must be firmly attached. If the cover panel is mounted incorrectly and dust and moisture enter the unit, electric shock or fire may result.
  - When installing or relocating, or servicing the air conditioner, use only the specified refrigerant (R32) to charge the refrigerant lines. Do not mix it with any other refrigerant and do not allow air to remain in the lines.  
 If air is mixed with the refrigerant, then it can be the cause of abnormal high pressure in the refrigerant line, and may result in an explosion and other hazards. The use of any refrigerant other than that specified for the system will cause mechanical failure or system malfunction or unit breakdown. In the worst case, this could lead to a serious impediment to securing product safety.
  - Use only accessories authorized by Mitsubishi Electric and ask a dealer or an authorized technician to install them. If accessories are incorrectly installed, water leakage, electric shock, or fire may result.
  - Do not alter the unit. It may cause fire, electric shock, injury or water leakage.
  - The user should never attempt to repair the unit or transfer it to another location. If the unit is installed incorrectly, water leakage, electric shock, or fire may result. If the air conditioner must be repaired or moved, ask a dealer or an authorized technician.
  - After installation has been completed, check for refrigerant leaks. If refrigerant leaks into the room and comes into contact with the flame of a heater or portable cooking range, poisonous gases will be released.
  - When opening or closing the valve below freezing temperatures, refrigerant may spurt out from the gap between the valve stem and the valve body, resulting in injuries.
  - Do not use means to accelerate the defrosting process or to clean, other than those recommended by the manufacturer.
  - The appliance shall be stored in a room without continuously operating ignition sources (for example: open flames, an operating gas appliance or an operating electric heater).
  - Do not pierce or burn.
  - Be aware that refrigerants may not contain an odour.

en

# 1. Safety precautions

## ⚠ Warning:

- ⊙ Pipe-work shall be protected from physical damage.
- The installation of pipe-work shall be kept to a minimum.
- Compliance with national gas regulations shall be observed.
- Keep any required ventilation openings clear of obstruction.
- ⊙ Do not use low temperature solder alloy in case of brazing the refrigerant pipes.
- ⊙ When performing brazing work, be sure to ventilate the room sufficiently. Make sure that there are no hazardous or flammable materials nearby. When performing the work in a closed room, small room, or similar location, make sure that there are no refrigerant leaks before performing the work. If refrigerant leaks and accumulates, it may ignite or poisonous gases may be released.
- ⊙ The appliance shall be stored in a well-ventilated area where the room size corresponds to the room area as specified for operation.
- ⊙ Keep gas-burning appliances, electric heaters, and other fire sources (ignition sources) away from the location where installation, repair, and other air conditioner work will be performed. If refrigerant comes into contact with a flame, poisonous gases will be released.
- ⊙ Do not smoke during work and transportation.
- Do not perform pump down work when there is a gas leak. The intake of air or other gases causes abnormally high pressure in the refrigeration cycle, which may cause explosion or injury.

## 1.1. Before installation

### ⚠ Caution:

- Do not use the unit in an unusual environment. If the air conditioner is installed in areas exposed to steam, volatile oil (including machine oil), or sulfuric gas, areas exposed to high salt content such as the seaside, or areas where the unit will be covered by snow, the performance can be significantly reduced and the internal parts can be damaged.
- Do not install the unit where combustible gases may leak, be produced, flow, or accumulate. If combustible gas accumulates around the unit, fire or explosion may result.
- The outdoor unit produces condensation during the heating operation. Make sure to provide drainage around the outdoor unit if such condensation is likely to cause damage.
- When installing the unit in a hospital or communications office, be prepared for noise and electronic interference. Inverters, home appliances, high-frequency medical equipment, and radio communications equipment can cause the air conditioner to malfunction or breakdown. The air conditioner may also affect medical equipment, disturbing medical care, and communications equipment, harming the screen display quality.

## 1.2. Before installation (relocation)

### ⚠ Caution:

- Be extremely careful when transporting or installing the units. Two or more persons are needed to handle the unit, as it weighs 20 kg or more. Do not grasp the packaging bands. Wear protective gloves to remove the unit from the packaging and to move it, as you can injure your hands on the fins or the edge of other parts.
- Be sure to safely dispose of the packaging materials. Packaging materials, such as nails and other metal or wooden parts may cause stabs or other injuries.
- The base and attachments of the outdoor unit must be periodically checked for looseness, cracks or other damage. If such defects are left uncorrected, the unit may fall down and cause damage or injuries.
- Do not clean the air conditioner unit with water. Electric shock may result.
- Tighten all flare nuts to specification using a torque wrench. If tightened too much, the flare nut can break after an extended period and refrigerant can leak out.

## 1.3. Before electric work

### ⚠ Caution:

- Be sure to install circuit breakers. If not installed, electric shock may result.
- For the power lines, use standard cables of sufficient capacity. Otherwise, a short circuit, overheating, or fire may result.
- When installing the power lines, do not apply tension to the cables. If the connections are loosened, the cables can snap or break and overheating or fire may result.
- Be sure to ground the unit. Do not connect the ground wire to gas or water pipes, lightning rods, or telephone grounding lines. If the unit is not properly grounded, electric shock may result.
- Use circuit breakers (ground fault interrupter, isolating switch (+B fuse), and molded case circuit breaker) with the specified capacity. If the circuit breaker capacity is larger than the specified capacity, breakdown or fire may result.

## 1.4. Before starting the test run

### ⚠ Caution:

- Turn on the main power switch more than 12 hours before starting operation. Starting operation just after turning on the power switch can severely damage the internal parts. Keep the main power switch turned on during the operation season.
- Before starting operation, check that all panels, guards and other protective parts are correctly installed. Rotating, hot, or high voltage parts can cause injuries.
- Do not touch any switch with wet hands. Electric shock may result.
- Do not touch the refrigerant pipes with bare hands during operation. The refrigerant pipes are hot or cold depending on the condition of the flowing refrigerant. If you touch the pipes, burns or frostbite may result.
- After stopping operation, be sure to wait at least five minutes before turning off the main power switch. Otherwise, water leakage or breakdown may result.

## 1.5. Using R32 refrigerant air conditioners

### ⚠ Caution:

- Use C1220 copper phosphorus, for copper and copper alloy seamless pipes, to connect the refrigerant pipes. Make sure the insides of the pipes are clean and do not contain any harmful contaminants such as sulfuric compounds, oxidants, debris, or dust. Use pipes with the specified thickness. (Refer to 4.1.) Note the following if reusing existing pipes that carried R22 refrigerant.
  - Replace the existing flare nuts and flare the flared sections again.
  - Do not use thin pipes. (Refer to 4.1.)
- Store the pipes to be used during installation indoors and keep both ends of the pipes sealed until just before brazing. (Leave elbow joints, etc. in their packaging.) If dust, debris, or moisture enters the refrigerant lines, oil deterioration or compressor breakdown may result.
- Use ester oil, ether oil, alkylbenzene oil (small amount) as the refrigeration oil applied to the flared sections. If mineral oil is mixed in the refrigeration oil, oil deterioration may result.
- Servicing shall be performed only as recommended by the manufacturer.
- Do not use refrigerant other than R32 refrigerant.
- Use the following tools specifically designed for use with R32 refrigerant. The following tools are necessary to use R32 refrigerant. Contact your nearest dealer for any questions.

Tools (for R32)	
Gauge manifold	Flare tool
Charge hose	Size adjustment gauge
Gas leak detector	Vacuum pump adapter
Torque wrench	Electronic refrigerant charging scale

- Be sure to use the correct tools. If dust, debris, or moisture enters the refrigerant lines, refrigeration oil deterioration may result.

## 2. Installation location

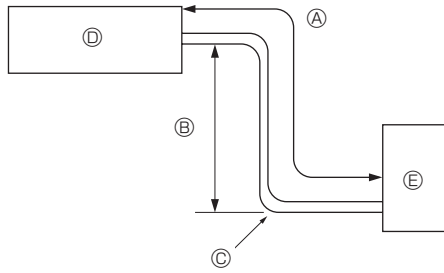

Fig. 2-1

### 2.1. Refrigerant pipe (Fig. 2-1)

► Check that the difference between the heights of the indoor and outdoor units, the length of refrigerant pipe, and the number of bends in the pipe are within the limits shown below.

Models	Ⓐ Pipe length (one way)	Ⓑ Height difference	Ⓒ Number of bends (one way)
ZM100, 125, 140	Max. 100 m	Max. 30 m	Max. 15

• Height difference limitations are binding regardless of which unit, indoor or outdoor, is positioned higher.

- Ⓓ Indoor unit
- Ⓔ Outdoor unit

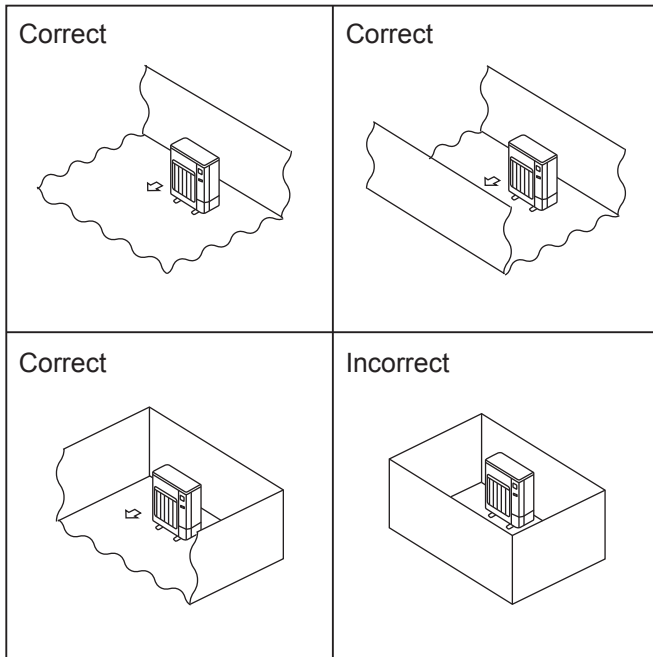

Fig. 2-2

### 2.2. Choosing the outdoor unit installation location

Ⓢ R32 is heavier than air—as well as other refrigerants—so tends to accumulate at the base (in the vicinity of the floor). If R32 accumulates around base, it may reach a flammable concentration in case room is small. To avoid ignition, maintaining a safe work environment is required by ensuring appropriate ventilation. If a refrigerant leak is confirmed in a room or an area where there is insufficient ventilation, refrain from using of flames until the work environment can be improved by ensuring appropriate ventilation.

- Avoid locations exposed to direct sunlight or other sources of heat.
- Select a location from which noise emitted by the unit will not inconvenience neighbors.
- Select a location permitting easy wiring and pipe access to the power source and indoor unit.
- Avoid locations where combustible gases may leak, be produced, flow, or accumulate.
- Note that water may drain from the unit during operation.
- Select a level location that can bear the weight and vibration of the unit.
- Avoid locations where the unit can be covered by snow. In areas where heavy snow fall is anticipated, special precautions such as raising the installation location or installing a hood on the air intake must be taken to prevent the snow from blocking the air intake or blowing directly against it. This can reduce the airflow and a malfunction may result.
- Avoid locations exposed to oil, steam, or sulfuric gas.
- Use the transportation handles of the outdoor unit to transport the unit. If the unit is carried from the bottom, hands or fingers may be pinched.
- Refrigerant pipes connection shall be accessible for maintenance purposes.
- Ⓢ Install outdoor units in a place where at least one of the four sides is open, and in a sufficiently large space without depressions. (Fig. 2-2)

en

## 2. Installation location

### 2.3. Outline dimensions (Outdoor unit) (Fig. 2-3)

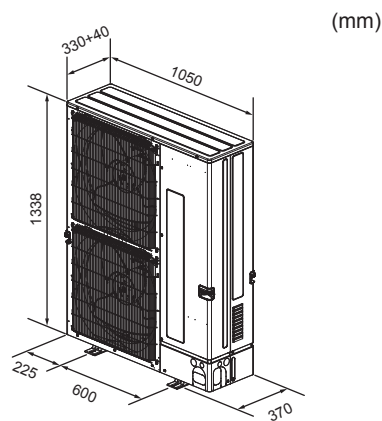

Fig. 2-3

### 2.4. Ventilation and service space

#### 2.4.1. Windy location installation

When installing the outdoor unit on a rooftop or other location unprotected from the wind, situate the air outlet of the unit so that it is not directly exposed to strong winds. Strong wind entering the air outlet may impede the normal airflow and a malfunction may result.

The following shows three examples of precautions against strong winds.

- ① Face the air outlet towards the nearest available wall about 500 mm away from the wall. (Fig. 2-4)
- ② Install an optional air protection guide if the unit is installed in a location where strong winds from a typhoon, etc. may directly enter the air outlet. (Fig. 2-5)
  - Ⓐ Air protection guide
- ③ Position the unit so that the air outlet blows perpendicularly to the seasonal wind direction, if possible. (Fig. 2-6)
  - Ⓑ Wind direction

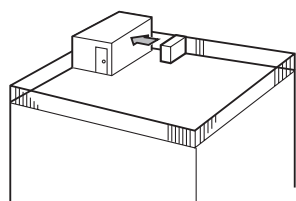

Fig. 2-4

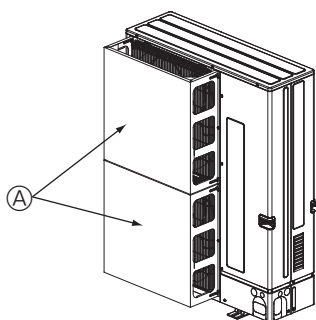

Fig. 2-5

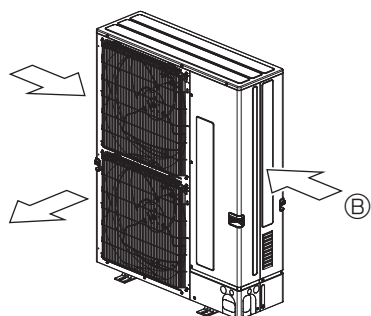

Fig. 2-6

## 2. Installation location

### 2.4.2. When installing a single outdoor unit

Minimum dimensions are as follows, except for Max., meaning Maximum dimensions, indicated.

Refer to the figures for each case.

- ① Obstacles at rear only (Fig. 2-7)
- ② Obstacles at rear and above only (Fig. 2-8)
- ③ Obstacles at rear and sides only (Fig. 2-9)
- ④ Obstacles at front only (Fig. 2-10)
- \* When using the optional air outlet guides, the clearance is 500 mm or more.
- ⑤ Obstacles at front and rear only (Fig. 2-11)
- \* When using the optional air outlet guides, the clearance is 500 mm or more.
- ⑥ Obstacles at rear, sides, and above only (Fig. 2-12)
- \* Do not install the optional air outlet guides for upward airflow.

### 2.4.3. When installing multiple outdoor units

Leave 50 mm space or more between the units.

- ① Obstacles at rear only (Fig. 2-13)
- ② Obstacles at rear and above only (Fig. 2-14)
- \* No more than 3 units must be installed side by side. In addition, leave space as shown.
- \* Do not install the optional air outlet guides for upward airflow.
- ③ Obstacles at front only (Fig. 2-15)
- \* When using the optional air outlet guides, the clearance is 1000 mm or more.
- ④ Obstacles at front and rear only (Fig. 2-16)
- \* When using the optional air outlet guides, the clearance is 1000 mm or more.
- ⑤ Single parallel unit arrangement (Fig. 2-17)
- \* When using the optional air outlet guides installed for upward airflow, the clearance is 1000 mm or more.
- ⑥ Multiple parallel unit arrangement (Fig. 2-18)
- \* When using the optional air outlet guides installed for upward airflow, the clearance is 1500 mm or more.
- ⑦ Stacked unit arrangement (Fig. 2-19)
- \* The units can be stacked up to 2 units high.
- \* No more than 2 stacked units must be installed side by side. In addition, leave space as shown.

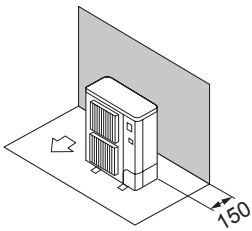

Fig. 2-7

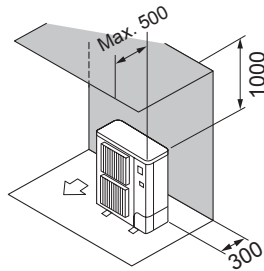

Fig. 2-8

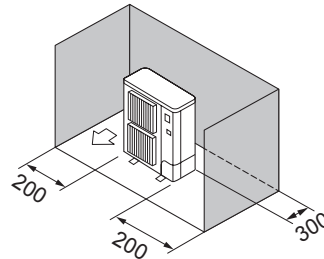

Fig. 2-9

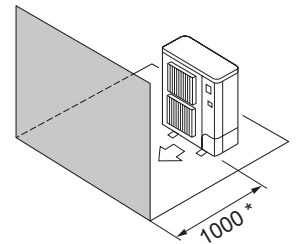

Fig. 2-10

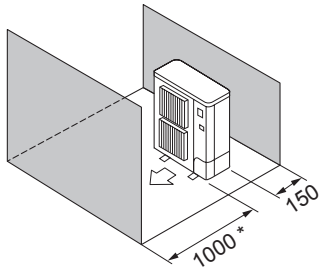

Fig. 2-11

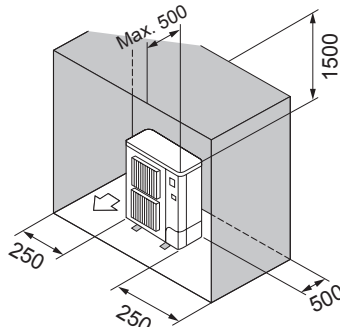

Fig. 2-12

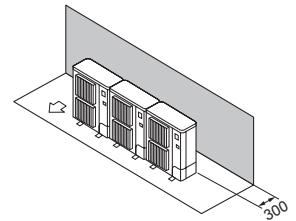

Fig. 2-13

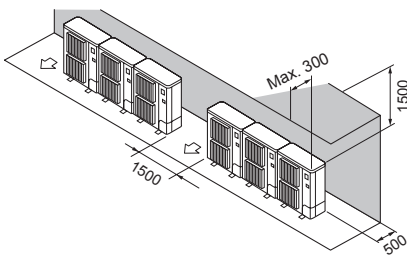

Fig. 2-14

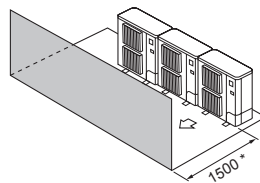

Fig. 2-15

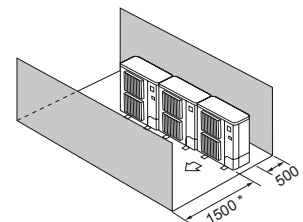

Fig. 2-16

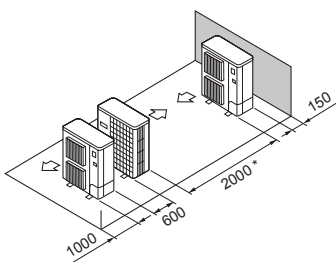

Fig. 2-17

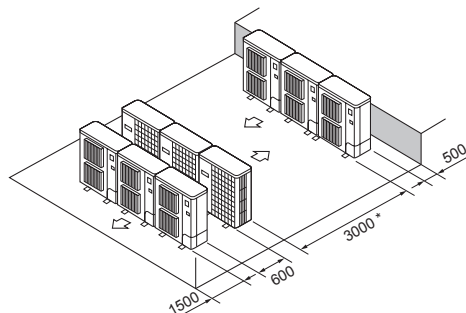

Fig. 2-18

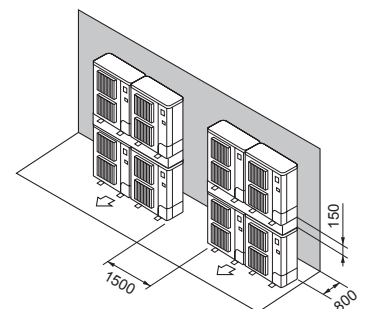

Fig. 2-19

(mm)

en

## 2. Installation location

### 2.5. Minimum installation area

If you unavoidably install a unit in a space where all four sides are blocked or there are depressions, confirm that one of these situations (A, B or C) is satisfied.

**Note: These countermeasures are for keeping safety not for specification guarantee.**

A) Secure sufficient installation space (minimum installation area  $A_{min}$ ).

Install in a space with an installation area of  $A_{min}$  or more, corresponding to refrigerant quantity M (factory-charged refrigerant + locally added refrigerant).

M [kg]	$A_{min}$ [m <sup>2</sup> ]
1.0	12
1.5	17
2.0	23
2.5	28
3.0	34
3.5	39
4.0	45
4.5	50
5.0	56
5.5	62
6.0	67
6.5	73
7.0	78
7.5	84
8.0	89
8.5	95
9.0	100
9.5	106

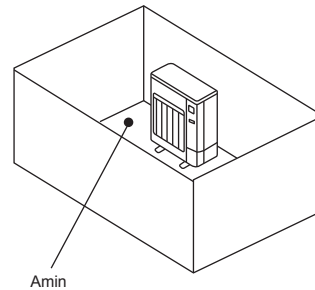

B) Install in a space with a depression height of  $\leq 0.125$  [m].

Height from the bottom of  
0.125 [m] or less

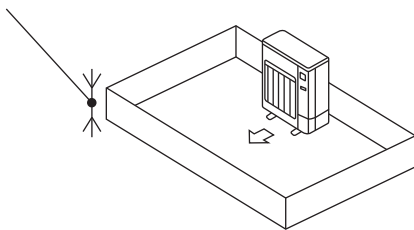

Height from the bottom of  
0.125 [m] or less

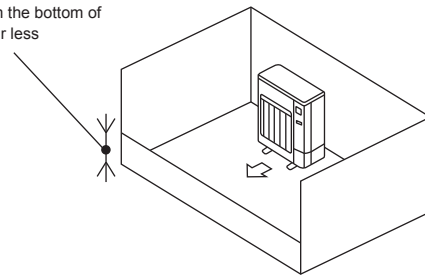

C) Create an appropriate ventilation open area.

Make sure that the width of the open area is 0.9 [m] or more and the height of the open area is 0.15 [m] or more.

However, the height from the bottom of the installation space to the bottom edge of the open area should be 0.125 [m] or less.

Open area should be 75% or more opening.

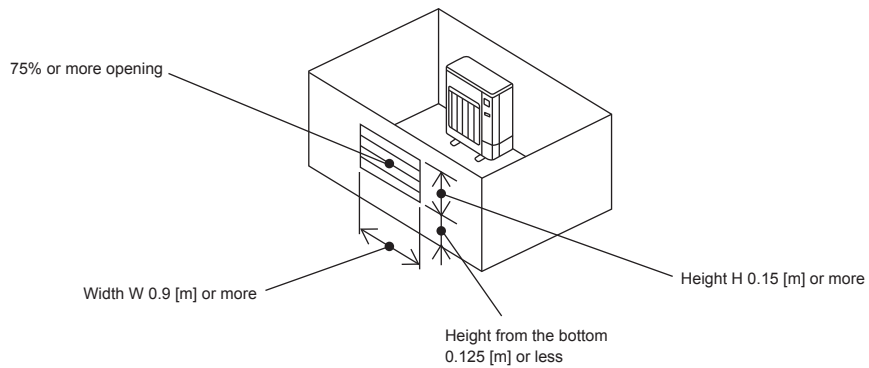



## 2. Installation location

### ■ Indoor units

Install in a room with a floor area of  $A_{min}$  or more, corresponding to refrigerant quantity M (factory-charged refrigerant + locally added refrigerant).

\* For the factory-charged refrigerant amount, refer to the spec nameplate or installation manual.

For the amount to be added locally, refer to the installation manual.

Install the indoor unit so that the height from the floor to the bottom of the indoor unit is  $h_0$ .

For wall mounted: 1.8 m or more

For ceiling suspended, cassette and ceiling concealed: 2.2 m or more

For floor standing (PSA-M): 0 m

\* There are restrictions in installation height for each model, so read the installation manual for the particular unit.

Case 1: for wall mounted, ceiling suspended, cassette and concealed

M [kg]	$A_{min}$ [m <sup>2</sup> ]
1.0	4
1.5	6
2.0	8
2.5	10
3.0	12
3.5	14
4.0	16
4.5	20
5.0	24
5.5	29
6.0	35
6.5	41
7.0	47
7.5	54
8.0	62
8.5	69
9.0	78
9.5	87

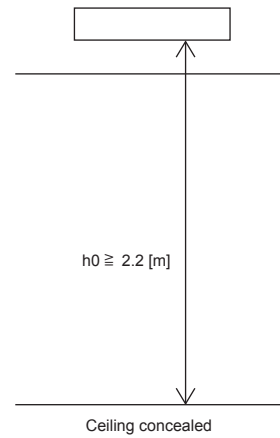
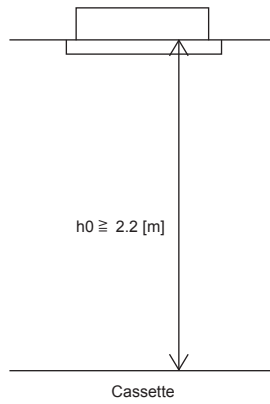
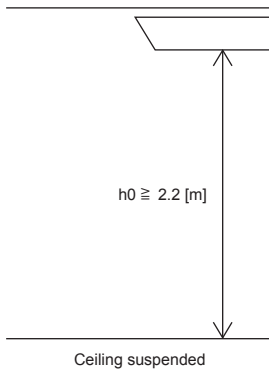
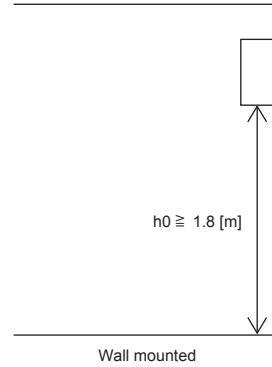

Case 2: for floor standing (PSA-M)

M [kg]	$A_{min}$ [m <sup>2</sup> ]
< 1.84	No requirements
1.84	6
2.0	6
2.5	7
3.0	9
3.5	10
4.0	11
4.5	13
5.0	14
5.5	15
6.0	17
6.5	18
7.0	20
7.5	21
8.0	22
8.5	24
9.0	25
9.5	26

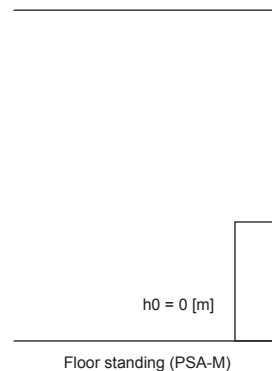

### 3. Installing the outdoor unit

(mm)

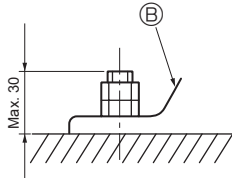
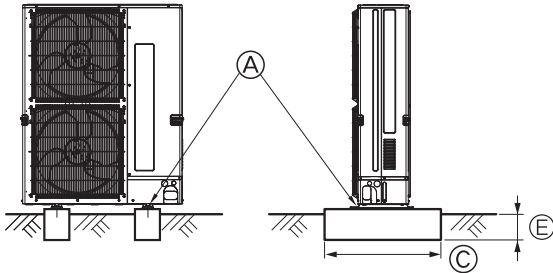

- Ⓐ M10 (3/8") bolt
- Ⓑ Base
- Ⓒ As long as possible.
- Ⓓ Vent
- Ⓔ Set deep in the ground

- Be sure to install the unit in a sturdy, level surface to prevent rattling noises during operation. (Fig. 3-1)

<Foundation specifications>

Foundation bolt	M10 (3/8")
Thickness of concrete	120 mm
Length of bolt	70 mm
Weight-bearing capacity	320 kg

- Make sure that the length of the foundation bolt is within 30 mm of the bottom surface of the base.
- Secure the base of the unit firmly with four-M10 foundation bolts in sturdy locations.

#### Installing the outdoor unit

- Do not block the vent. If the vent is blocked, operation will be hindered and breakdown may result.
- In addition to the unit base, use the installation holes on the back of the unit to attach wires, etc., if necessary to install the unit. Use self-tapping screws (ø5 × 15 mm or less) and install on site.

#### ⚠ Warning:

- **The unit must be securely installed on a structure that can sustain its weight. If the unit is mounted on an unstable structure, it may fall down and cause damage or injuries.**
- **The unit must be installed according to the instructions in order to minimize the risk of damage from earthquakes, typhoons, or strong winds. An incorrectly installed unit may fall down and cause damage or injuries.**

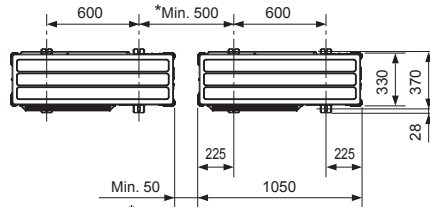
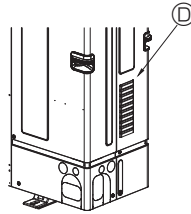

\* When installing a single outdoor unit, the clearance is 15 mm or more.

Fig. 3-1

### 4. Installing the refrigerant piping

#### 4.1. Precautions for devices that use R32 refrigerant

- Refer to 1.5. for precautions not included below on using air conditioners with R32 refrigerant.
  - Use ester oil, ether oil, alkylbenzene oil (small amount) as the refrigeration oil applied to the flared sections.
  - Use C1220 copper phosphorus, for copper and copper alloy seamless pipes, to connect the refrigerant pipes. Use refrigerant pipes with the thicknesses specified in the table to the below. Make sure the insides of the pipes are clean and do not contain any harmful contaminants such as sulfuric compounds, oxidants, debris, or dust.
- Always apply no-oxidation brazing when brazing the pipes, otherwise, the compressor will be damaged.

#### ⚠ Warning:

When installing or relocating, or servicing the air conditioner, use only the specified refrigerant (R32) to charge the refrigerant lines. Do not mix it with any other refrigerant and do not allow air to remain in the lines.

If air is mixed with the refrigerant, then it can be the cause of abnormal high pressure in the refrigerant line, and may result in an explosion and other hazards.

The use of any refrigerant other than that specified for the system will cause mechanical failure or system malfunction or unit breakdown. In the worst case, this could lead to a serious impediment to securing product safety.

Pipe size (mm)	ø6.35	ø9.52	ø12.7	ø15.88	ø19.05	ø22.2	ø25.4	ø28.58
Thickness (mm)	0.8	0.8	0.8	1.0	1.0	1.0	1.0	1.0

- Do not use pipes thinner than those specified above.
- Use 1/2 H or H pipes if the diameter is 19.05 mm or larger.
- Be sure to have appropriate ventilation in order to prevent ignition. Furthermore, be sure to carry out fire prevention measures that there are no dangerous or flammable objects in the surrounding area.

## 4. Installing the refrigerant piping

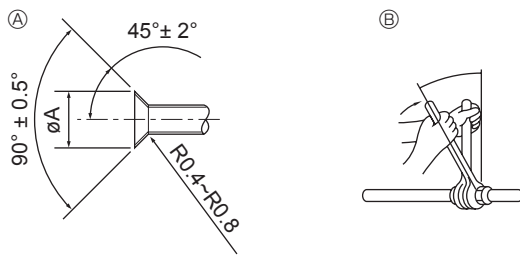

- Ⓐ Flare cutting dimensions  
Ⓑ Flare nut tightening torque

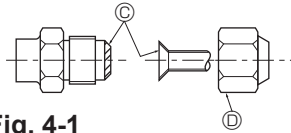

Fig. 4-1

Ⓐ (Fig. 4-1)

Copper pipe O.D. (mm)	Flare dimensions øA dimensions (mm)
ø6.35	8.7 - 9.1
ø9.52	12.8 - 13.2
ø12.7	16.2 - 16.6
ø15.88	19.3 - 19.7
ø19.05	23.6 - 24.0

Ⓑ (Fig. 4-1)

Copper pipe O.D. (mm)	Flare nut O.D. (mm)	Tightening torque (N·m)
ø6.35	17	14 - 18
ø6.35	22	34 - 42
ø9.52	22	34 - 42
ø12.7	26	49 - 61
ø12.7	29	68 - 82
ø15.88	29	68 - 82
ø15.88	36	100 - 120
ø19.05	36	100 - 120

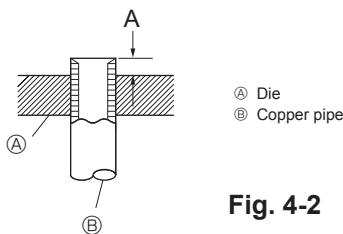

Fig. 4-2

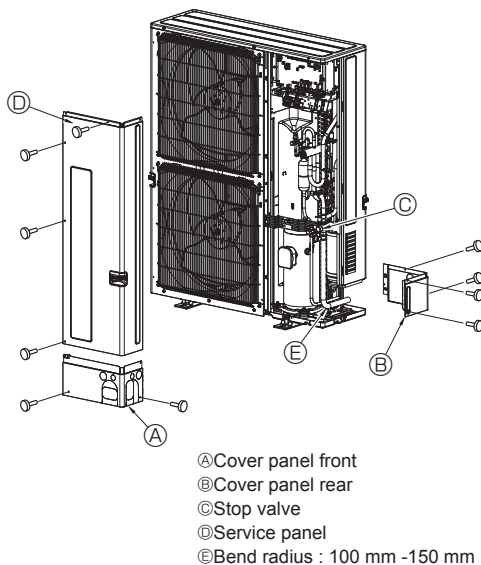

Fig. 4-3

### 4.2. Connecting pipes (Fig. 4-1)

- When commercially available copper pipes are used, wrap liquid and gas pipes with commercially available insulation materials (heat-resistant to 100 °C or more, thickness of 12 mm or more).
- The indoor parts of the drain pipe should be wrapped with polyethylene foam insulation materials (specific gravity of 0.03, thickness of 9 mm or more).
- Apply thin layer of refrigerant oil to pipe and joint seating surface before tightening flare nut. Ⓐ
- Use two wrenches to tighten piping connections. Ⓑ
- Use leak detector or soapy water to check for gas leaks after connections are completed.
- Apply refrigerating machine oil over the entire flare seat surface. Ⓒ
- Use the flare nuts for the following pipe size. Ⓓ

		ZM100-140
Gas side	Pipe size (mm)	ø15.88
Liquid side	Pipe size (mm)	ø9.52

- When bending the pipes, be careful not to break them. Bend radii of 100 mm to 150 mm are sufficient.
- Make sure the pipes do not contact the compressor. Abnormal noise or vibration may result.
- ① Pipes must be connected starting from the indoor unit. Flare nuts must be tightened with a torque wrench.
- ② Flare the liquid pipes and gas pipes and apply a thin layer of refrigeration oil (Applied on site).
- When usual pipe sealing is used, refer to Table 1 for flaring of R32 refrigerant pipes. The size adjustment gauge can be used to confirm A measurements.

Table 1 (Fig. 4-2)

Copper pipe O.D. (mm)	A (mm)	
	Flare tool for R32	Flare tool for R22·R407C
	Clutch type	
ø6.35 (1/4")	0 - 0.5	1.0 - 1.5
ø9.52 (3/8")	0 - 0.5	1.0 - 1.5
ø12.7 (1/2")	0 - 0.5	1.0 - 1.5
ø15.88 (5/8")	0 - 0.5	1.0 - 1.5
ø19.05 (3/4")	0 - 0.5	1.0 - 1.5

### 4.3. Refrigerant piping (Fig. 4-3)

Remove the service panel Ⓓ (4 screws) and the cover panel front Ⓐ (2 screws) and cover panel rear Ⓑ (4 screws).

- Perform refrigerant piping connections for the indoor/outdoor unit when the outdoor unit's stop valve is completely closed.
- Vacuum-purge air from the indoor unit and the connection piping.
- After connecting the refrigerant pipes, check the connected pipes and the indoor unit for gas leaks. (Refer to 4.4. Refrigerant pipe airtight testing method)
- A high-performance vacuum pump is used at the stop valve service port to maintain a vacuum for an adequate time (at least one hour after reaching -101 kPa (5 Torr)) in order to vacuum dry the inside of the pipes. Always check the degree of vacuum at the gauge manifold. If there is any moisture left in the pipe, the degree of vacuum is sometimes not reached with short-time vacuum application. After vacuum drying, completely open the stop valves (both liquid and gas) for the outdoor unit. This completely links the indoor and outdoor refrigerant circuits.
  - If the vacuum drying is inadequate, air and water vapor remain in the refrigerant circuits and can cause abnormal rise of high pressure, abnormal drop of low pressure, deterioration of the refrigerating machine oil due to moisture, etc.
  - If the stop valves are left closed and the unit is operated, the compressor and control valves will be damaged.
  - Use a leak detector or soapy water to check for gas leaks at the pipe connection sections of the outdoor unit.
  - Do not use the refrigerant from the unit to purge air from the refrigerant lines.
  - After the valve work is completed, tighten the valve caps to the correct torque: 20 to 25 N·m (200 to 250 kgf·cm). Failure to replace and tighten the caps may result in refrigerant leakage. In addition, do not damage the insides of the valve caps as they act as a seal to prevent refrigerant leakage.
- Use sealant to seal the ends of the thermal insulation around the pipe connection sections to prevent water from entering the thermal insulation.

## 4. Installing the refrigerant piping

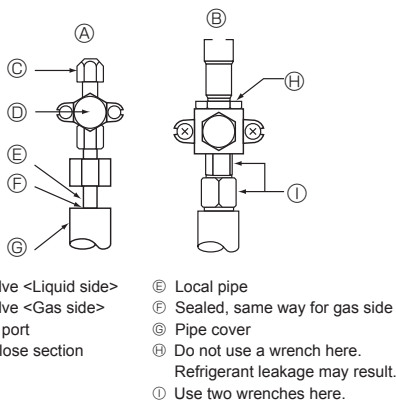

Fig. 4-4

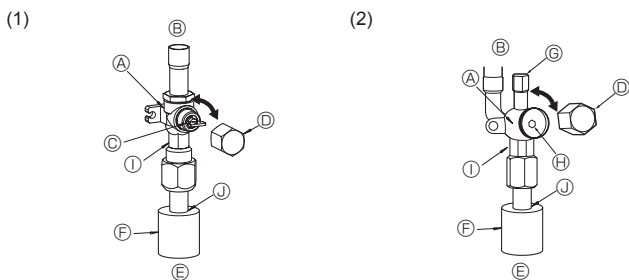

Fig. 4-5

Fig. 4-6

- Ⓐ Valve body
- Ⓑ Unit side
- Ⓒ Handle
- Ⓓ Cap
- Ⓔ Local pipe side
- Ⓕ Pipe cover
- Ⓖ Service port
- Ⓗ Valve stem
- Ⓘ Double spanner section  
(Do not apply a spanner other than to this section. Doing so would cause coolant leaks.)
- ⓿ Seal section  
(Seal the end of the heat insulation material at the pipe connection section with whatever seal material you have on hand so that water does not infiltrate the heat insulation material.)

### 4.4. Refrigerant pipe airtight testing method (Fig. 4-4)

- (1) Connect the testing tools.
  - Make sure the stop valves Ⓐ Ⓑ are closed and do not open them.
  - Add pressure to the refrigerant lines through the service port Ⓒ of the liquid stop valve Ⓐ.
- (2) Do not add pressure to the specified pressure all at once; add pressure little by little.
  - ① Pressurize to 0.5 MPa (5 kgf/cm<sup>2</sup>G), wait five minutes, and make sure the pressure does not decrease.
  - ② Pressurize to 1.5 MPa (15 kgf/cm<sup>2</sup>G), wait five minutes, and make sure the pressure does not decrease.
  - ③ Pressurize to 4.15 MPa (41.5 kgf/cm<sup>2</sup>G) and measure the surrounding temperature and refrigerant pressure.
- (3) If the specified pressure holds for about one day and does not decrease, the pipes have passed the test and there are no leaks.
  - If the surrounding temperature changes by 1 °C, the pressure will change by about 0.01 MPa (0.1 kgf/cm<sup>2</sup>G). Make the necessary corrections.
- (4) If the pressure decreases in steps (2) or (3), there is a gas leak. Look for the source of the gas leak.

### 4.5. Stop valve opening method

The stop valve opening method varies according to the outdoor unit model. Use the appropriate method to open the stop valves.

- (1) Gas side (Fig. 4-5)
  - ① Remove the cap, pull the handle toward you and rotate 1/4 turn in a counterclockwise direction to open.
  - ② Make sure that the stop valve is open completely, push in the handle and rotate the cap back to its original position.
- (2) Liquid side (Fig. 4-6)
  - ① Remove the cap and turn the valve rod counterclockwise as far as it will go with the use of a 4 mm hexagonal wrench. Stop turning when it hits the stopper. (ø9.52: Approximately 10 revolutions)
  - ② Make sure that the stop valve is open completely, push in the handle and rotate the cap back to its original position.

Refrigerant pipes are protectively wrapped

- The pipes can be protectively wrapped up to a diameter of ø90 before or after connecting the pipes. Cut out the knockout in the pipe cover following the groove and wrap the pipes.

Pipe inlet gap

- Use putty or sealant to seal the pipe inlet around the pipes so that no gaps remain. (If the gaps are not closed, noise may be emitted or water and dust will enter the unit and breakdown may result.)

### Precautions when using the charge valve (Fig. 4-7)

Do not tighten the service port too much when installing it, otherwise, the valve core could be deformed and become loose, causing a gas leak.

After positioning section Ⓑ in the desired direction, turn section Ⓐ only and tighten it. Do not further tighten sections Ⓐ and Ⓑ together after tightening section Ⓐ.

#### ⚠ Warning:

- When installing the unit, securely connect the refrigerant pipes before starting the compressor.
- When opening or closing the valve below freezing temperatures, refrigerant may spurt out from the gap between the valve stem and the valve body, resulting in injuries.

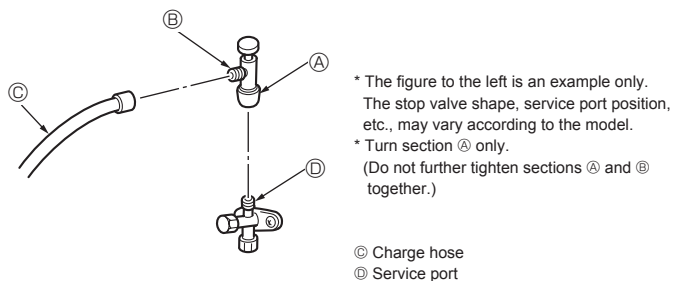

Fig. 4-7

- \* The figure to the left is an example only. The stop valve shape, service port position, etc., may vary according to the model.
- \* Turn section Ⓐ only. (Do not further tighten sections Ⓐ and Ⓑ together.)

- Ⓒ Charge hose
- Ⓓ Service port

### 4.6. Addition of refrigerant

- Additional charging is not necessary if the pipe length does not exceed 30 m.
- If the pipe length exceeds 40 m, charge the unit with additional R32 refrigerant according to the permitted pipe lengths in the chart below.
  - \* When the unit is stopped, charge the unit with the additional refrigerant through the liquid stop valve after the pipe extensions and indoor unit have been vacuumized.
  - When the unit is operating, add refrigerant to the gas check valve using a safety charger. Do not add liquid refrigerant directly to the check valve.
  - \* After charging the unit with refrigerant, note the added refrigerant amount on the service label (attached to the unit).
  - Refer to the "1.5. Using R32 refrigerant air conditioners" for more information.

- Be careful when installing multiple units. Connecting to an incorrect indoor unit can lead to abnormally high pressure and have a serious effect on operation performance.
- ⓸ R32 maintenance refilling: Before servicing refilling the equipment with R32 to ensure that there is no risk of explosion from electrical sparks it must be ensured that the equipment machine is 100% disconnected from the mains supply.

Model	Permitted pipe length	Permitted vertical difference	Additional refrigerant charging amount				⓸Maximum amount of refrigerant
			41 - 50 m	51 - 60 m	61 - 75 m	75 - 100 m	
ZM100-140	- 100 m	- 30 m	0.4 kg	0.8 kg	1.4 kg	2.4 kg	6.0 kg

## 4. Installing the refrigerant piping

Refilling refrigerant charge (kg) for less than 40 m (Chargeless pipe length)

Outdoor unit	5 m and less	6 - 10 m	11 - 15 m	16 - 20 m	21 - 25 m	26 - 30 m	31 - 40 m
ZM100-140	3.0	3.1	3.2	3.3	3.4	3.5	3.6

### 4.7. Precautions when reusing existing R22 refrigerant pipes

- Refer to the flowchart below to determine if the existing pipes can be used and if it is necessary to use a filter dryer.
- If the diameter of the existing pipes is different from the specified diameter, refer to technological data materials to confirm if the pipes can be used.

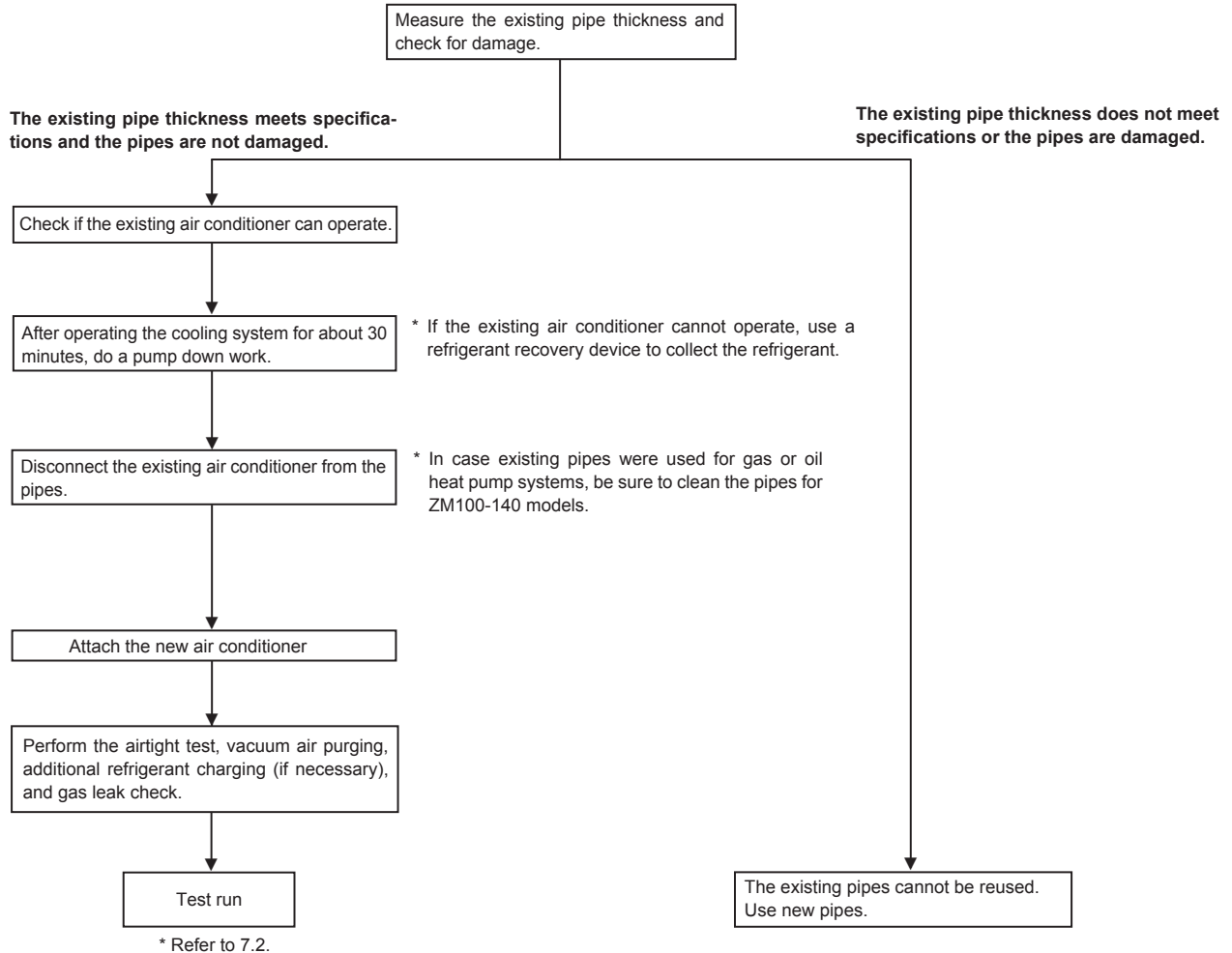

<Limits of refrigerant piping installation>

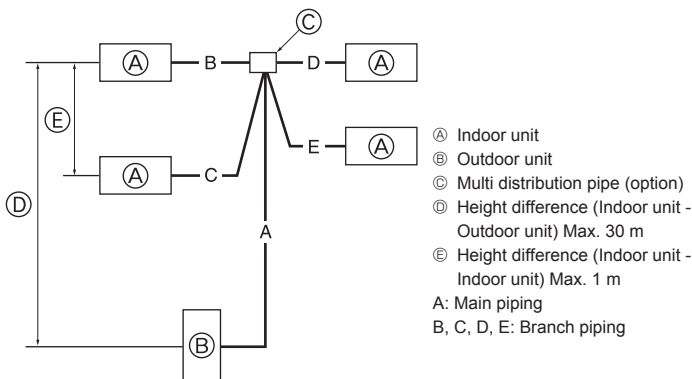

ZM100-140 :  $A+B+C(+D) \leq 100$  m

\* "D" is for triple.

\* "E" is for four (quadruple).

### 4.8. For twin/triple/quadruple combination (Fig. 4-8)

- When this unit is used as a FREE COMPO MULTI unit, install the refrigerant piping with the restrictions indicated in the drawing on the left. In addition, if the restrictions are going to be exceeded, or if there are going to be combinations of indoor and outdoor units, refer to installation instructions for the indoor unit for details about the installation.

Outdoor unit	Permissible total piping length A+B+C+D+E	A+B or A+C or A+D or A+E	Charge-less piping length A+B+C+D+E
ZM100-140	100 m and less	—	30 m and less

Outdoor unit	B-C   or   B-D   or   B-E   or   C-D   or   C-E   or   D-E	No. of bends
ZM100-140	8 m and less	Within 15

Fig. 4-8

## 5. Drainage piping work

### Outdoor unit drainage pipe connection

When drain piping is necessary, use the drain socket or the drain pan (option).

	ZM100-140
Drain socket	PAC-SG61DS-E
Drain pan	PAC-SH97DP-E

## 6. Electrical work

### 6.1. Outdoor unit (Fig. 6-1, Fig. 6-2)

- ① Remove the service panel.
- ② Wire the cables referring to the Fig. 6-1 and the Fig. 6-2.

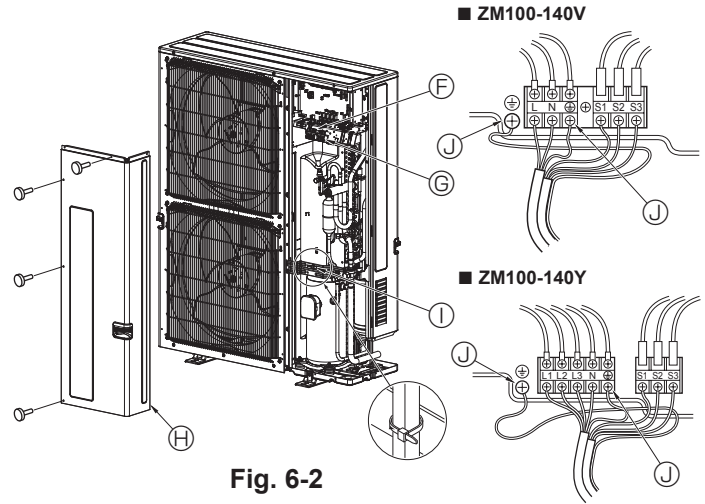
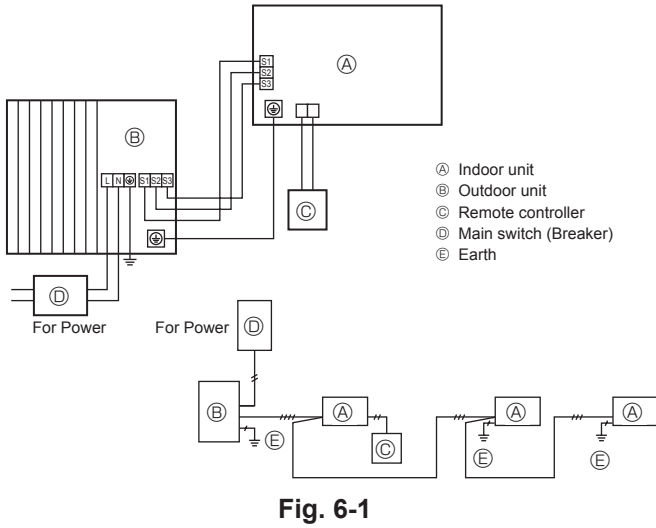

- F Terminal block  
 G Indoor/Outdoor connection terminal block (S1, S2, S3)  
 H Service panel  
 I Clamp  
 \* Clamp the cables so that they do not contact the center of the service panel or the gas valve.  
 J Earth terminal

**Note :**  
If the protective sheet for the electrical box is removed during servicing, be sure to reinstall it.

**Caution:**  
Be sure to install N-Line. Without N-Line, it could cause damage to unit.

## 6. Electrical work

### 6.2. Field electrical wiring

Outdoor unit model		ZM100,125V	ZM140V	ZM100, 125, 140Y
Outdoor unit power supply		~N (single), 50 Hz, 230 V	~N (single), 50 Hz, 230 V	3N~ (3 ph 4-wires), 50 Hz, 400 V
Outdoor unit input capacity Main switch (Breaker)		*1 32 A	40 A	16 A
Wiring Wire No. x size (mm <sup>2</sup> )	Outdoor unit power supply	*5 3 x Min. 4	3 x Min. 6	5 x Min. 1.5
	Indoor unit-Outdoor unit	*2 3 x 1.5 (Polar)	3 x 1.5 (Polar)	3 x 1.5 (Polar)
	Indoor unit-Outdoor unit earth	*2 1 x Min. 1.5	1 x Min. 1.5	1 x Min. 1.5
Remote controller-Indoor unit		*3 2 x 0.3 (Non-polar)	2 x 0.3 (Non-polar)	2 x 0.3 (Non-polar)
Circuit rating	Outdoor unit L-N (single)	*4 230 VAC	230 VAC	230 VAC
	Outdoor unit L1-N, L2-N, L3-N (3 phase)	*4 230 VAC	230 VAC	230 VAC
	Indoor unit-Outdoor unit S1-S2	*4 28 VDC	28 VDC	28 VDC
	Indoor unit-Outdoor unit S2-S3	*4 12 VDC	12 VDC	12 VDC

\*1. A breaker with at least 3.0 mm contact separation in each poles shall be provided. Use earth leakage breaker (NV).

Make sure that the current leakage breaker is one compatible with higher harmonics.

Always use a current leakage breaker that is compatible with higher harmonics as this unit is equipped with an inverter.

The use of an inadequate breaker can cause the incorrect operation of inverter.

\*2. (ZM100-140)

Max. 45 m

If 2.5 mm<sup>2</sup> used, Max. 50 m

If 2.5 mm<sup>2</sup> used and S3 separated, Max. 80 m

\*3. The 10 m wire is attached in the remote controller accessory.

\*4. The figures are NOT always against the ground.

S3 terminal has 28 VDC against S2 terminal. However between S3 and S1, these terminals are NOT electrically insulated by the transformer or other device.

\*5. In multi-phase appliances, the colour of the neutral conductor of the supply cord, if any, shall be blue.



**Notes:** 1. Wiring size must comply with the applicable local and national code.

2. Power supply cords and Indoor/Outdoor unit connecting cords shall not be lighter than polychloroprene sheathed flexible cord. (Design 60245 IEC 57)

3. Use an earth wire which is longer than the other cords so that it will not become disconnected when tension is applied.

4. Use self-extinguishing distribution cables for power supply wiring.

5. Properly route wiring so as not to contact the sheet metal edge or a screw tip.

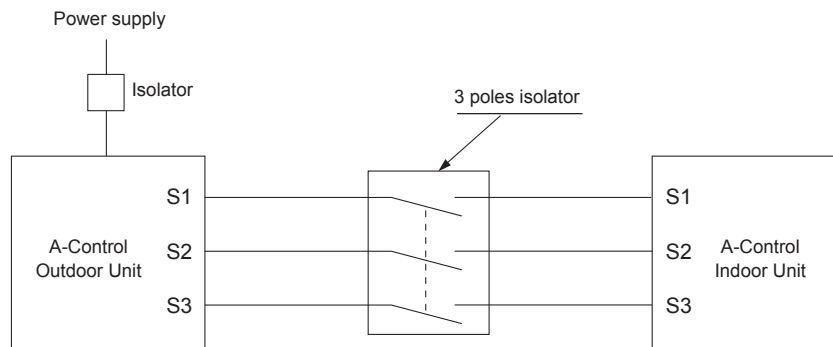

#### ⚠ Warning:

- In case of A-control wiring, there is high voltage potential on the S3 terminal caused by electrical circuit design that has no electrical insulation between power line and communication signal line. Therefore, please turn off the main power supply when servicing. And do not touch the S1, S2, S3 terminals when the power is energized. If isolator should be used between indoor unit and outdoor unit, please use 3-pole type.

Never splice the power cable or the indoor-outdoor connection cable, otherwise it may result in a smoke, a fire or communication failure.

Be sure to connect the indoor-outdoor connecting cables directly to the units (no intermediate connections).

Intermediate connections can lead to communication error if water enters the cables and causes insufficient insulation to ground or a poor electrical contact at the intermediate connection point.

## 7. Test run

### 7.1. Before test run

- ▶ After completing installation and the wiring and piping of the indoor and outdoor units, check for refrigerant leakage, looseness in the power supply or control wiring, wrong polarity, and no disconnection of one phase in the supply.
- ▶ Use a 500-volt megohmmeter to check that the resistance between the power supply terminals and ground is at least 1 MΩ.
- ▶ Do not carry out this test on the control wiring (low voltage circuit) terminals.

⚠ **Warning:**

Do not use the air conditioner if the insulation resistance is less than 1 MΩ.

#### Insulation resistance

After installation or after the power source to the unit has been cut for an extended period, the insulation resistance will drop below 1 MΩ due to refrigerant accumulating in the compressor. This is not a malfunction. Perform the following procedures.

1. Remove the wires from the compressor and measure the insulation resistance of the compressor.
2. If the insulation resistance is below 1 MΩ, the compressor is faulty or the resistance dropped due to the accumulation of refrigerant in the compressor.
3. After connecting the wires to the compressor, the compressor will start to warm up after power is supplied. After supplying power for the times indicated below, measure the insulation resistance again.

- The insulation resistance drops due to accumulation of refrigerant in the compressor. The resistance will rise above 1 MΩ after the compressor is warmed up for 4 hours.  
(The time necessary to warm up the compressor varies according to atmospheric conditions and refrigerant accumulation.)
  - To operate the compressor with refrigerant accumulated in the compressor, the compressor must be warmed up at least 12 hours to prevent breakdown.
4. If the insulation resistance rises above 1 MΩ, the compressor is not faulty.

⚠ **Caution:**

- The compressor will not operate unless the power supply phase connection is correct.
- Turn on the power at least 12 hours before starting operation.
- Starting operation immediately after turning on the main power switch can result in severe damage to internal parts. Keep the power switch turned on during the operational season.

#### ▶ The followings must be checked as well.

- The outdoor unit is not faulty. LED1 and LED2 on the control board of the outdoor unit flash when the outdoor unit is faulty.
- Both the gas and liquid stop valves are completely open.
- A protective sheet covers the surface of the DIP switch panel on the control board of the outdoor unit. Remove the protective sheet to operate the DIP switches easily.

## 7.2. Test run

### 7.2.1. Using SW4 in outdoor unit

SW4-1	ON	Cooling operation
SW4-2	OFF	
SW4-1	ON	Heating operation
SW4-2	ON	

\* After performing the test run, set SW4-1 to OFF.

- After power is supplied, a small clicking noise may be heard from the inside of the outdoor unit. The electronic expansion valve is opening and closing. The unit is not faulty.
- A few seconds after the compressor starts, a clanging noise may be heard from the inside of the outdoor unit. The noise is coming from the check valve due to the small difference in pressure in the pipes. The unit is not faulty.

The test run operation mode cannot be changed by DIP switch SW4-2 during the test run. (To change the test run operation mode during the test run, stop the test run by DIP switch SW4-1. After changing the test run operation mode, resume the test run by switch SW4-1.)

### 7.2.2. Using remote controller

Refer to the indoor unit installation manual.

**Note :**

Occasionally, vapor that is made by the defrost operation may seem as if smoke come up from the outdoor unit.

## 8. Special functions

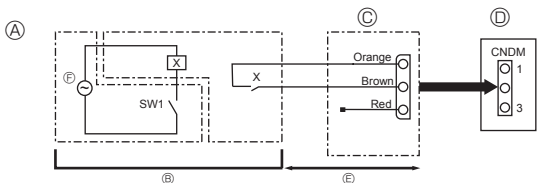

Fig. 8-1

- Ⓐ Circuit diagram example (low noise mode)    Ⓓ Outdoor unit control board  
 Ⓑ On-site arrangement    Ⓔ Max. 10 m  
 Ⓒ External input adapter (PAC-SC36NA-E)    Ⓕ Power supply for relay  
 X: Relay

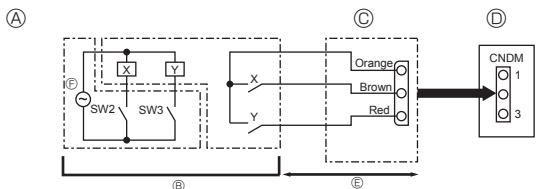

Fig. 8-2

- Ⓐ Circuit diagram example (Demand function)    Ⓒ External input adapter (PAC-SC36NA-E)  
 Ⓑ On-site arrangement    Ⓓ Outdoor unit control board  
 X, Y: Relay    Ⓔ Max. 10 m  
 Ⓕ Power supply for relay

### 8.1. Low noise mode (on-site modification) (Fig. 8-1)

By performing the following modification, operation noise of the outdoor unit can be reduced by about 3-4 dB.

The low noise mode will be activated when a commercially available timer or the contact input of an ON/OFF switch is added to the CNDM connector (option) on the control board of the outdoor unit.

- The ability varies according to the outdoor temperature and conditions, etc.
- ① Complete the circuit as shown when using the external input adapter (PAC-SC36NA-E). (Option)
  - ② SW7-1 (Outdoor unit control board): OFF
  - ③ SW1 ON: Low noise mode  
SW1 OFF: Normal operation

### 8.2. Demand function (on-site modification) (Fig. 8-2)

By performing the following modification, energy consumption can be reduced to 0-100% of the normal consumption.

The demand function will be activated when a commercially available timer or the contact input of an ON/OFF switch is added to the CNDM connector (option) on the control board of the outdoor unit.

- ① Complete the circuit as shown when using the external input adapter (PAC-SC36NA-E). (Option)
- ② By setting SW7-1 on the control board of the outdoor unit, the energy consumption (compared to the normal consumption) can be limited as shown below.

	SW7-1	SW2	SW3	Energy consumption
Demand function	ON	OFF	OFF	100%
		ON	OFF	75%
		ON	ON	50%
		OFF	ON	0% (Stop)



## 8. Special functions

### 8.3. Refrigerant collecting (pump down)

Perform the following procedures to collect the refrigerant when moving the indoor unit or the outdoor unit.

- ① Supply power (circuit breaker).
  - \* When power is supplied, make sure that "CENTRALLY CONTROLLED" is not displayed on the remote controller. If "CENTRALLY CONTROLLED" is displayed, the refrigerant collecting (pump down) cannot be completed normally.
  - \* Start-up of the indoor-outdoor communication takes about 3 minutes after the power (circuit breaker) is turned on. Start the pump-down operation 3 to 4 minutes after the power (circuit breaker) is turned ON.
- ② After the liquid stop valve is closed, set the SWP switch on the control board of the outdoor unit to ON. The compressor (outdoor unit) and ventilators (indoor and outdoor units) start operating and refrigerant collecting operation begins. LED1 and LED2 on the control board of the outdoor unit are lit.
  - \* Only set the SWP switch (push-button type) to ON if the unit is stopped. However, even if the unit is stopped and the SWP switch is set to ON less than 3 minutes after the compressor stops, the refrigerant collecting operation cannot be performed. Wait until compressor has been stopped for 3 minutes and then set the SWP switch to ON again.

- ③ Because the unit automatically stops in about 2 to 3 minutes when the refrigerant collecting operation is completed (LED1 off, LED2 lit), be sure to quickly close the gas stop valve. If LED1 is lit and LED2 is off and the outdoor unit is stopped, refrigerant collection is not properly performed. Open the liquid stop valve completely, and then repeat step ② after 3 minutes have passed.
  - \* If the refrigerant collecting operation has been completed normally (LED1 off, LED2 lit), the unit will remain stopped until the power supply is turned off.

- ④ Turn off the power supply (circuit breaker).
  - \* Note that when the extension piping is very long with large refrigerant amount, it may not be possible to perform a pump-down operation. When performing the pump-down operation, make sure that the low pressure is lowered to near 0 MPa (gauge).

#### ⚠ Warning:

- When pumping down the refrigerant, stop the compressor before disconnecting the refrigerant pipes. The compressor may burst if air etc. get into it.
- Do not perform pump down work when there is a gas leak. The intake of air or other gases causes abnormally high pressure in the refrigeration cycle, which may cause explosion or injury.

## 9. System control (Fig. 9-1)

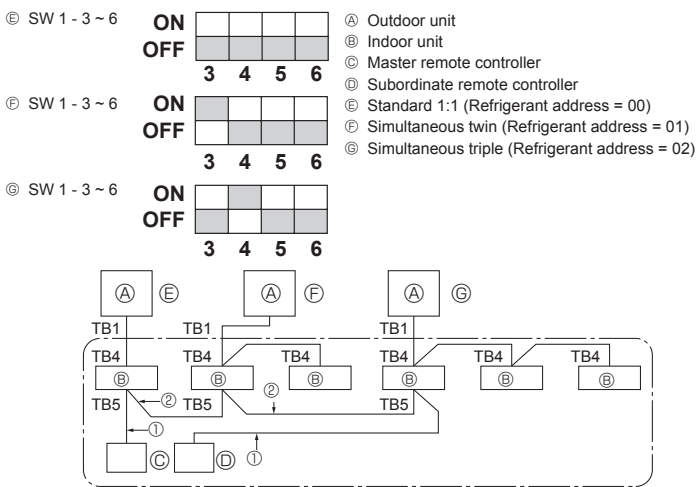

Fig. 9-1

\* Set the refrigerant address using the DIP switch of the outdoor unit.

- ① Wiring from the Remote Control  
This wire is connected to TB5 (terminal board for remote controller) of the indoor unit (non-polar).
- ② When a Different Refrigerant System Grouping is Used.  
Up to 16 refrigerant systems can be controlled as one group using the slim MA remote controller.

#### Note:

In single refrigerant system (twin/triple), there is no need of wiring ②.

SW1  
Function table

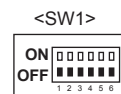

Function	Operation according to switch setting	
	ON	OFF
1 Compulsory defrosting	Start	Normal
2 Error history clear	Clear	Normal
3 Refrigerant system address setting	Settings for outdoor unit addresses 0 to 15	

## 10. Specifications

Outdoor model	ZM100V	ZM125V	ZM140V	ZM100Y	ZM125Y	ZM140Y
Power supply (V / Phase / Hz)	230 / Single / 50			400 / Three / 50		
Dimensions (W × H × D)	mm 1050 × 1338 × 330 (+40)					
Sound level *1	Cooling	49	50	50	49	50
	Heating	51	52	52	51	52

\*1 Measured under rated operation frequency.